

Power supplies  
1.2V, 2.5V, 3.3V

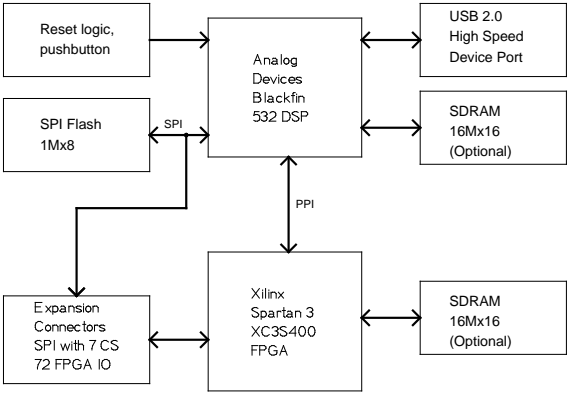

DSP address/data bus

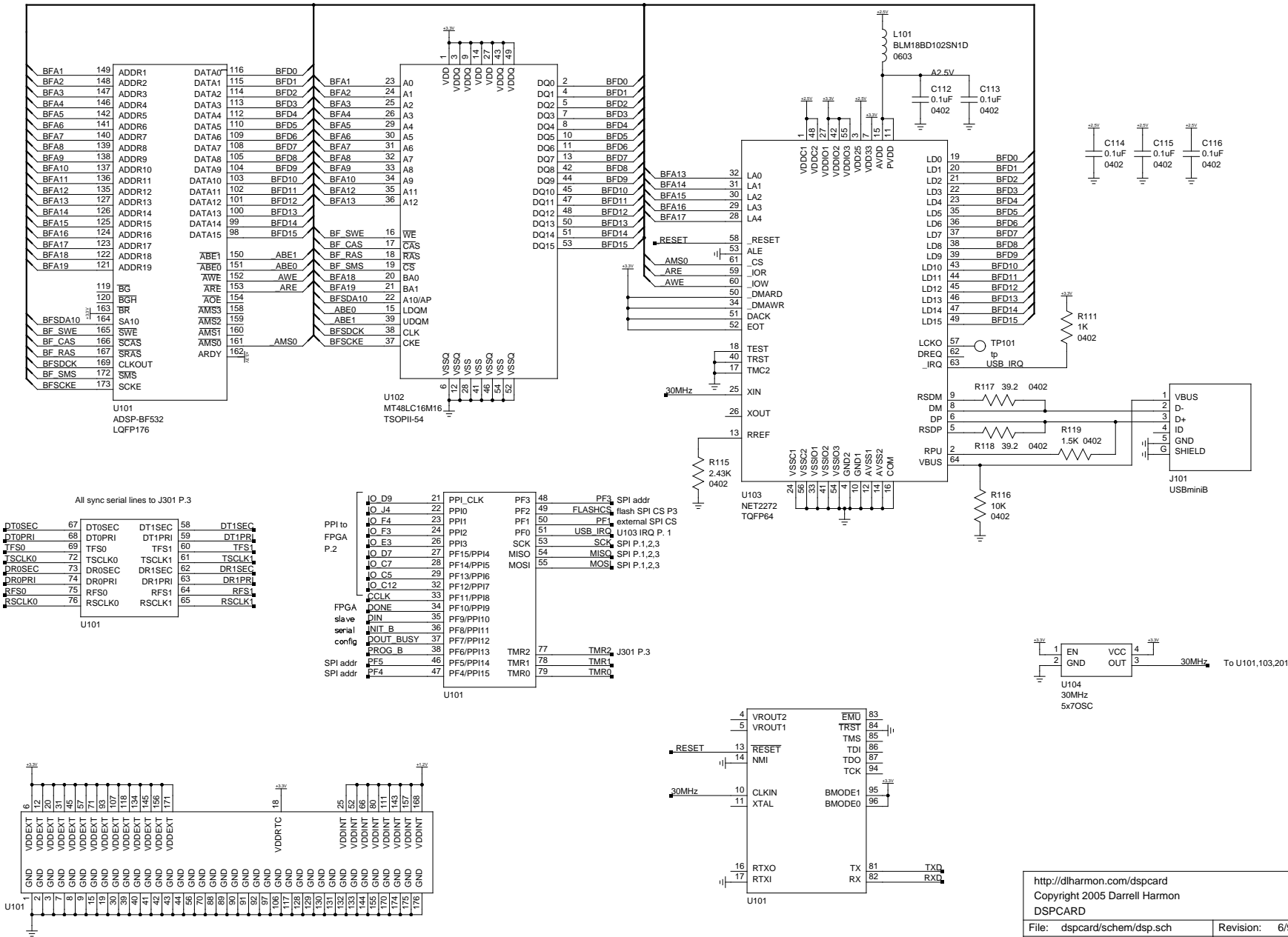

All serial sync lines to J301 P.3

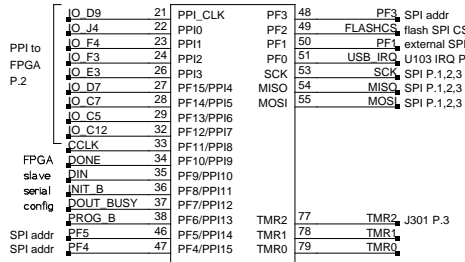
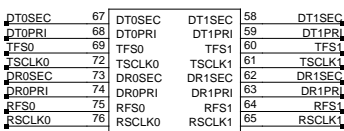

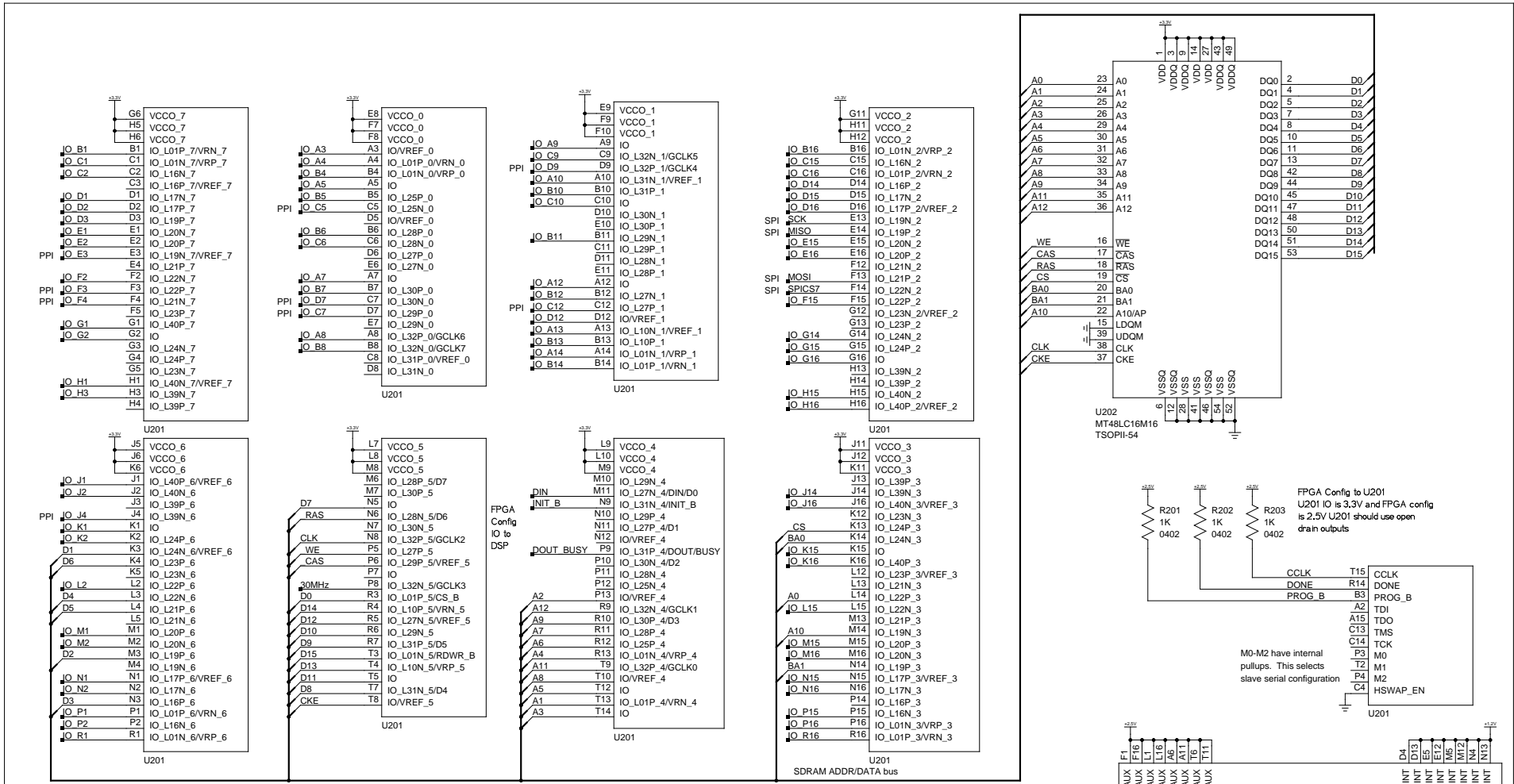

http://diharmon.com/fpgacard  
 Copyright 2005 Darrell Harmon  
 FPGACARD

File: fpgacard/schem/fpga.sch	Revision: 6/7/2005
Page 2 of 3	Drawn by: Darrell Harmon

